

CorkSport Performance

CX50-6-100 & -101 Cat Back & Axle Back Exhaust

Installation Instructions for the CorkSport Performance Cat Back and Axle Back Exhaust for the 2023+ Mazda CX50 AWD

Written By: Quintin Gunn



INTRODUCTION

In this installation guide we have provided step by step instructions to install the CorkSport Performance Cat Back and Axle Back Exhaust for the 2023+ Mazda CX50 AWD

Advisory:

- Working under the vehicle requires a safe and sturdy location for the vehicle to sit on jackstands.
- Exhaust will be hot after vehicle operation let the vehicle and/or direct a fan on the rear section of the exhaust to cool before attempting to work on the vehicle.

TOOLS:

- 10mm Socket - Deep (1)
- 10mm Wrench (1)
- 12mm Socket (1)
- 14mm Socket - Deep (1)
- 17mm Wrench (1)
- 17mm socket (1)
- 22mm wrench (1)
- Flathead Screwdriver (1)
- Jack Stand Set (1)
- Friend (1)

Step 1 — Getting Started



- First and foremost; THANK YOU for becoming a part of the CorkSport Family. We hope to bring you the highest level of Parts, Customer Service, & Support
- ① How To Use These Instructions
 - The instruction format will relate colored marking in the image to the color dot in the text to the right of the image
- ① Assistance from another person is recommended for some portions of the installation
- ① The vehicle used in this guide is equipped with the Turbocharged 2.5L Engine. Installation for Naturally Aspirated (Non-turbo) models will be identical
- ⚠ Ensure the car is completely cool before working on the vehicle to avoid burn injury

Step 2 — Lifting the Car

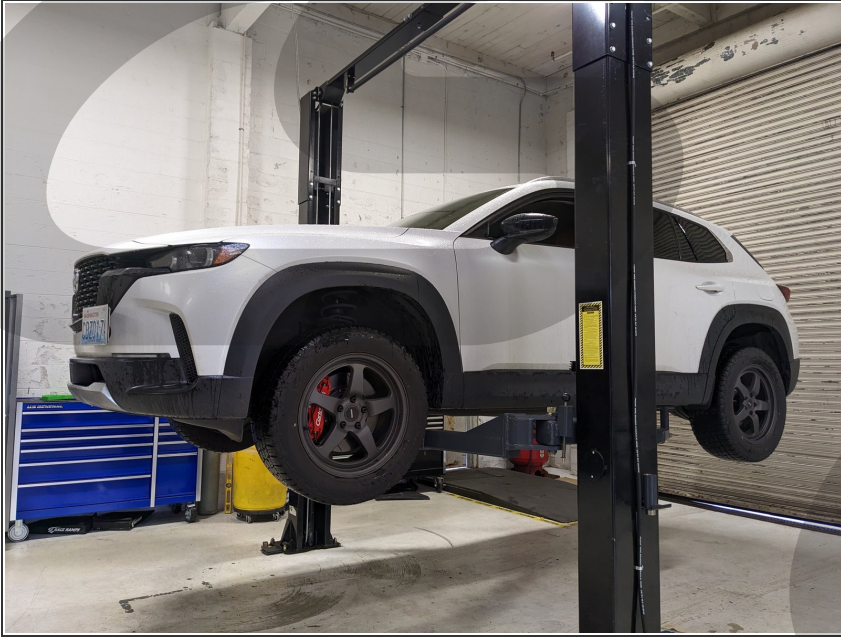

- ⚠️ Ensure the vehicle is parked on a level surface before proceeding.
- ⚠️ Be sure to reference your owner's manual for jack points and the jack manufacturer's instructions for proper practices.
- Lift the vehicle with a Hydraulic Jack and secure with Jack Stands

Step 3 — Unbolt the OEM Axleback Exhaust

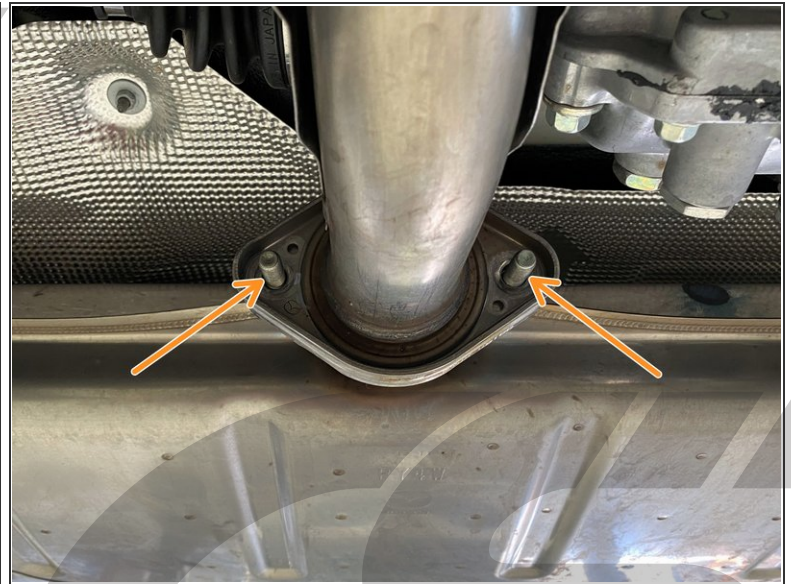
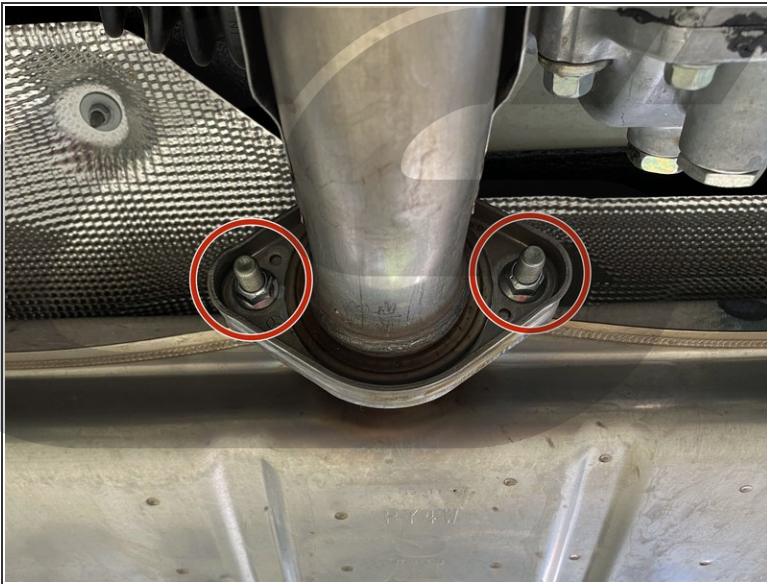

- Using a 14mm socket and ratchet, remove the two nuts that connect the OEM axle back section to the OEM midpipe section.
- Keep the OEM axle back section's studs inside the holes of the midpipe section. This helps support the axle back during removal.

Step 4 — Remove OEM Axleback - Part 1

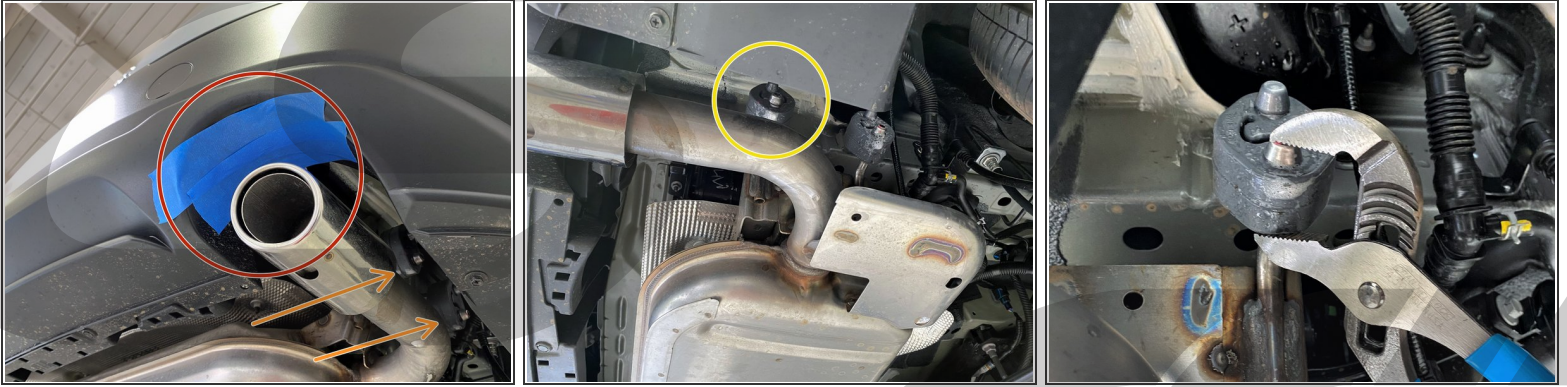

- **OPTIONAL:** Use painters tape in the exhaust cutouts in your bumper as shown to prevent damage. This is optional but will help prevent any scratches during removal & installation.
 - Spray the four rubber exhaust hangers with spray lubricant. (WD40, silicone spray, or even glass cleaner works well). The hangers are located on the sides of the exhaust as shown.
 - Using channel lock pliers or exhaust hanger pliers, disconnect the OEM axle back exhaust from the **Rearmost** rubber exhaust hangers. There is one on each side of the exhaust.
- ⓘ The third image shows how to use channel lock pliers to remove the rubber hangers for reference. Exhaust hanger pliers are easier to use if available.

Step 5 — Remove OEM Axleback - Part 2

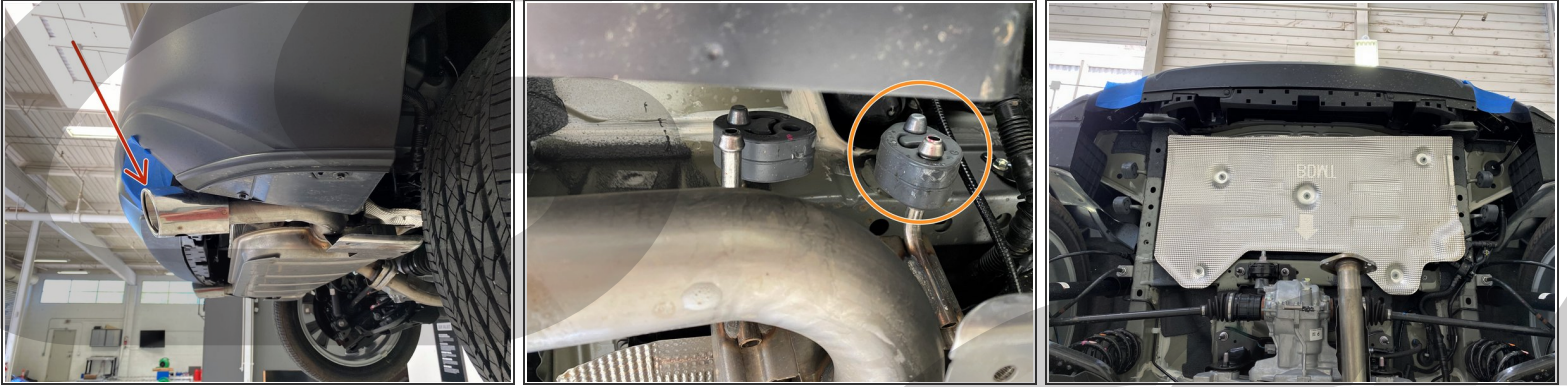

- Your exhaust should be pivoted downward as shown.
- ⚠ For the next step, support the axleback as you remove it from the final rubber hangers to keep it from falling to the ground or onto you. The easiest way is to get a friend to help or use a floor jack for support.
- Using channel lock pliers or exhaust hanger pliers, disconnect the OEM axle back exhaust from the two remaining rubber exhaust hangers, then remove the axle back from your vehicle.
- Upon removal, your vehicle will look like the third image.

Step 6 — Which Exhaust System are you installing?



- If you are installing the CS Catback Exhaust (Axleback *and* Midpipes), continue to the next step of this guide
- If you are only installing the CS Axleback Exhaust, please skip to **Step 17**

Step 7 — Remove Underbody Components - Part 1

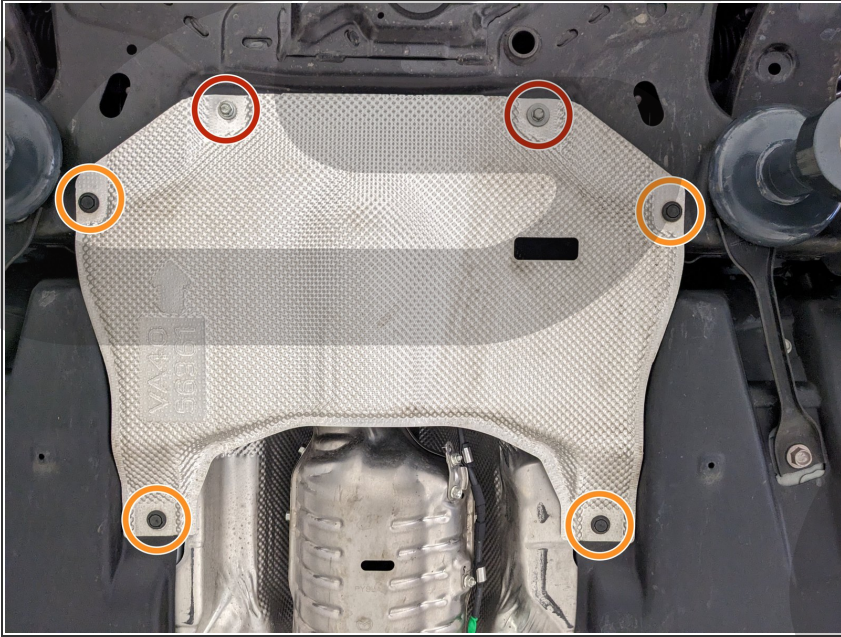

- Remove the Two(2) 10mm Bolts
- Remove the Four(4) Plastic Fasteners with a flathead screwdriver
- Remove the Silver heat shield from the vehicle and set aside

Step 8 — Remove Underbody Components - Part 2

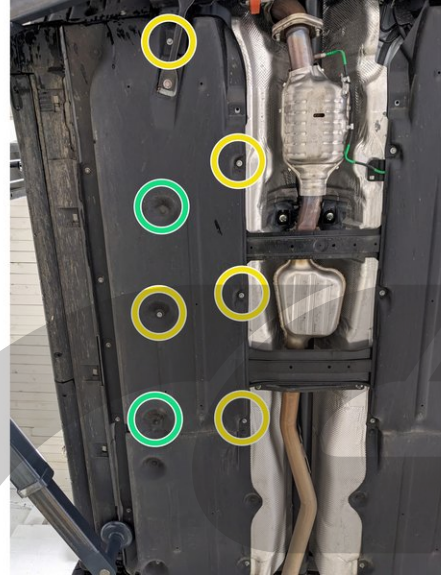
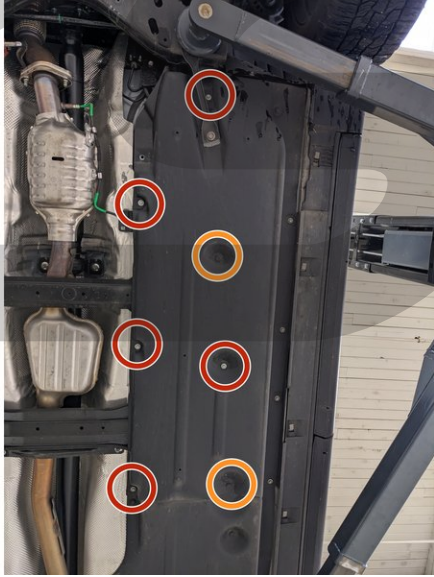

- Partially remove the Left side Plastic undertray by removing:
 - Five(5) 10mm bolts
 - Two(2) plastic push pins with a flathead screwdriver
- Partially remove the Right side plastic undertray by removing:
 - Five(5) 10mm bolts
 - Two(2) plastic push pins with a flathead screwdriver
- ① Allow the trays to hang to gain access to the Bracing shown in the next step

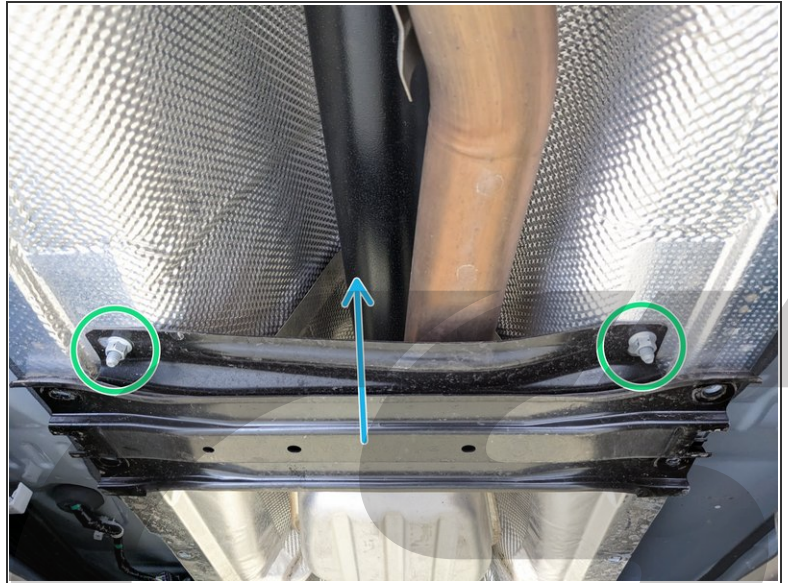
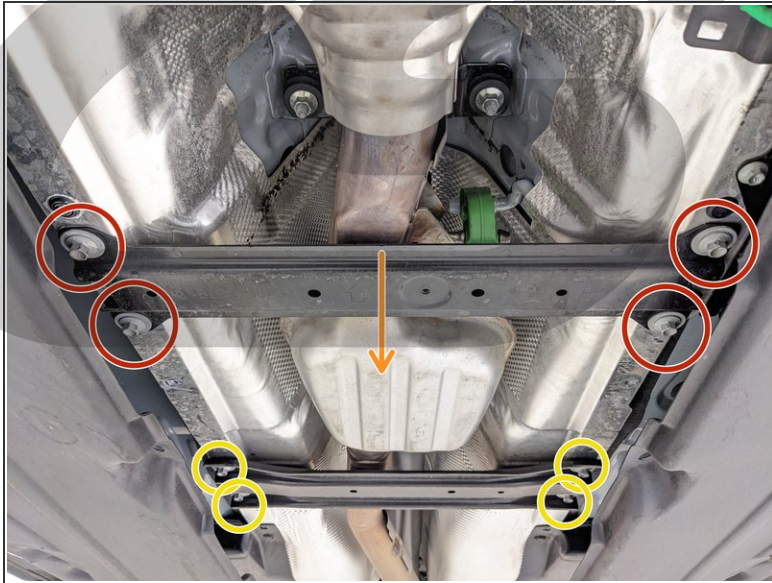
Step 9 — Remove Underbody Components - Part 3

- Remove the Four(4) 12mm bolts on the Front Underside Bracing
- Remove the Front Underside Bracing by pushing rearwards. The Brace should drop and be able to be removed from the car
- Remove the Four(4) 12mm bolts on the Rear Underside Bracing
- Remove the Two(2) 12mm Nuts on the Rear side of the Rear Underside Bracing
- Remove the Rear Underside Bracing by pushing rearwards. The Brace should drop and be able to be removed from the car

Step 10 — Non-Turbo Vehicles - Disconnect Cylinder Deactivation System

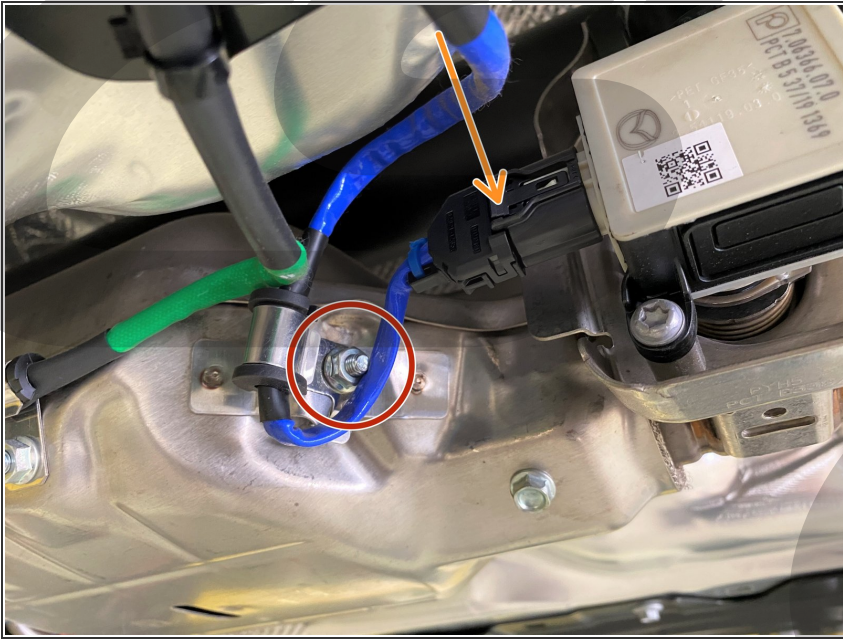

- ① This step is only necessary if your car is Non-Turbo and equipped with cylinder deactivation.
- Unbolt the single 10mm nut securing the wiring for the cylinder deactivation valve motor.
- Unplug the connector by depressing the tab and pulling.

Step 11 — Remove OEM Midpipe

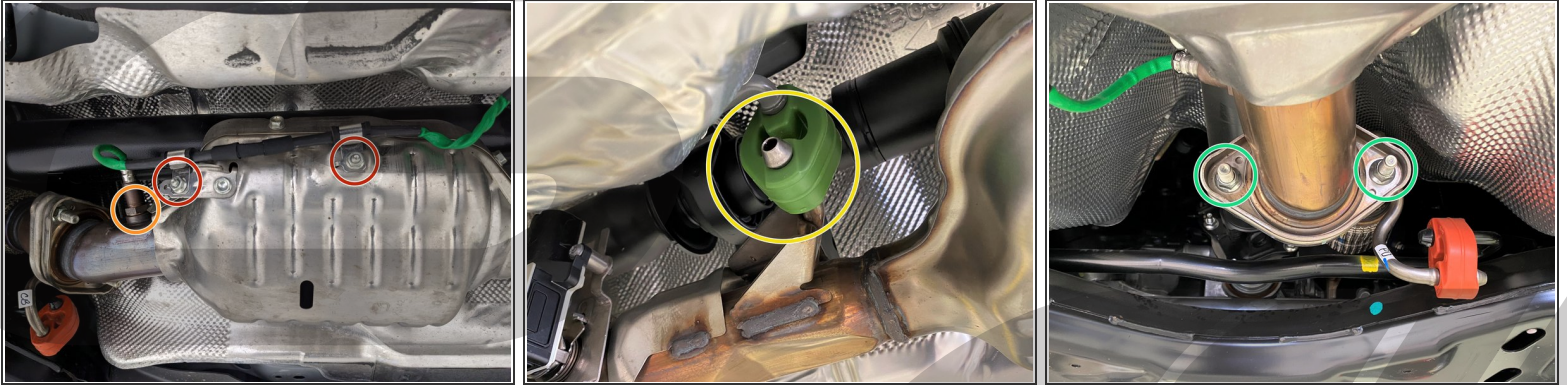

- Remove the Two(2) 10mm nuts securing the O2 Sensor Wiring to the exhaust midpipe
- With a 22mm wrench or an O2 Sensor Socket, remove the O2 sensor from the Midpipe
 - ⓘ Store in a safe place that is out of the way. The plastic skidtray on the left side is recommended
- ⚠ Place a jack stand under or have a friend help support the rear of the midpipe to prevent it from falling upon performing the following steps
- Using channel lock or exhaust hanger pliers, remove the midpipe hanger
 - ⓘ Silicone spray is recommended for lubricant. Glass cleaner works great as well
- Remove the Two(2) 14mm nuts securing the midpipe to the Downpipe/header. (it is okay if the studs come out with the nut, just be sure not to drop the midpipe)
- Remove the Midpipe from the vehicle by sliding the pipe rearward and off of the studs

Step 12 — Non-Turbo Vehicles - Removing and Installing the Cylinder Deactivation Valve Motor

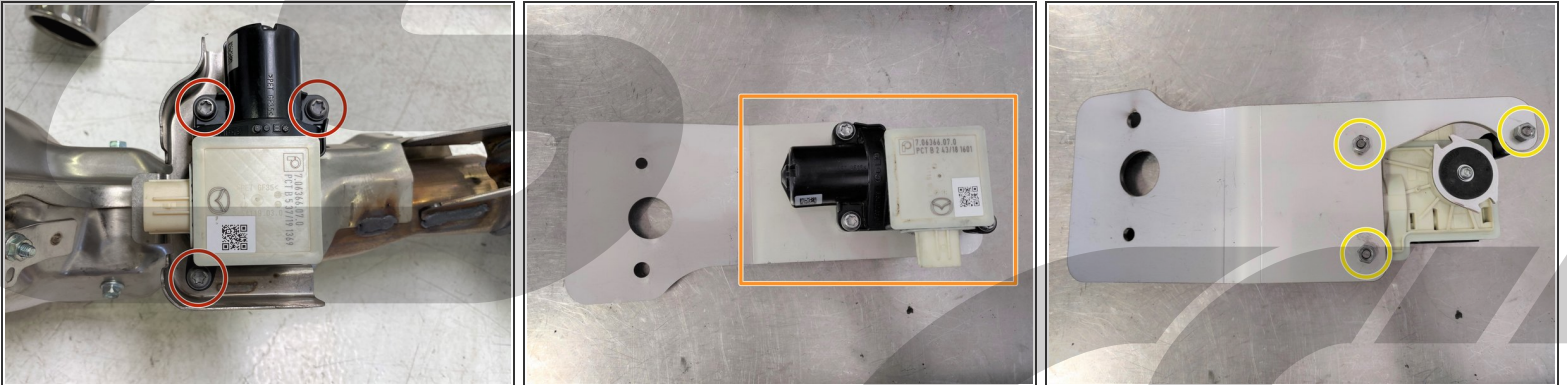

- ❗ This step is only necessary if your car is Non-Turbo and equipped with cylinder deactivation
- Remove the three bolts holding the cylinder deactivation valve motor to the OEM midpipe by using a T30 Torx bit and an 8mm wrench.
- Take the included cylinder deactivation motor bracket and reinstall the motor using the OEM hardware as shown.
- Using the same T30 Torx bit and 8mm wrench tighten the 3 bolts until they are all hand tight.
- Set aside for later assembly

Step 13 — Prepare CS Catback Midpipes

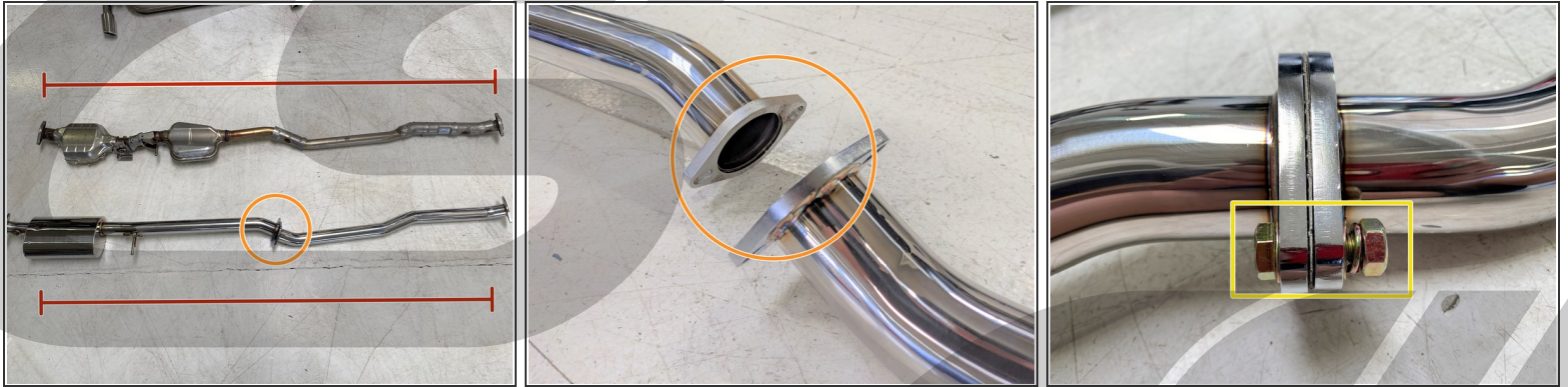

- Gather the Front and Rear midpipe sections and place them as shown
- ***Ensure the small flange with slots is placed in the center***
- Align center flanges and install the included hardware
 - ⓘ The hardware is assembled (going from left to right): bolt, washer, flange, gasket, flange, washer, lock washer, then nut.
 - ⓘ Use the small gasket that matches with shape of the flange
- **Tighten to 45 ft-lb (61 Nm)**
- Ensure flanges remain aligned after tightening

Step 14 — Install CS Catback Midpipes

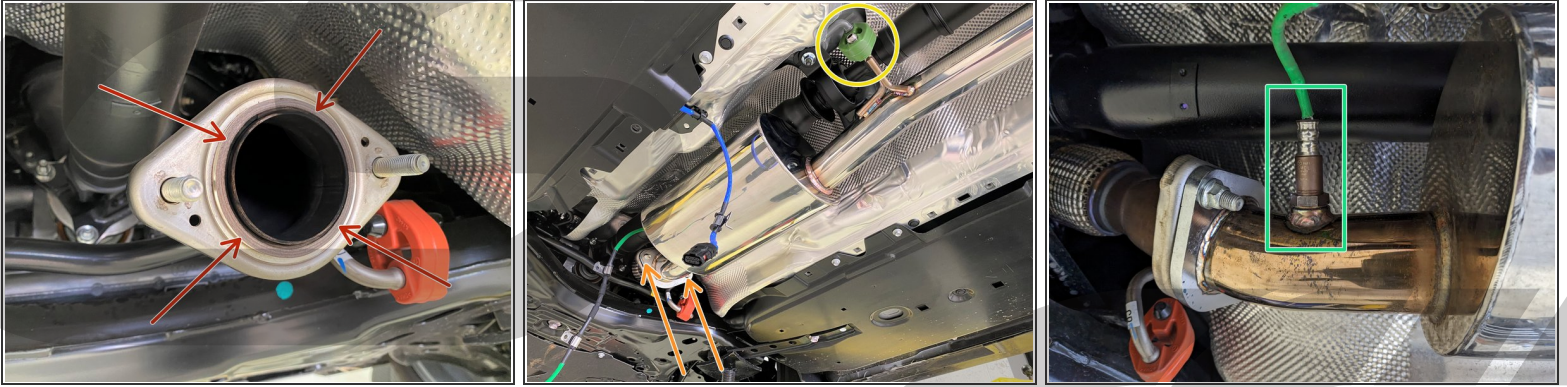

- Check the Downpipe/Header and make sure the OEM gasket is still in place.
 - ⓘ Check for damage before reusing. If the gasket is damaged, the Mazda OEM part number is: PE23-40-305
- ⚠ Place a jack stand under or have a friend help support the rear of the midpipe to prevent it from falling upon performing the following steps
- Lift the connected midpipe section and slide the front flange onto the Downpipe/header studs
- Install the midpipe onto the Exhaust Hanger
- Ensure the front flange is aligned with the Downpipe/header flange and Install the OEM 14mm nuts, then tighten to **35 ft-lb (47 Nm)**
 - ⓘ The studs in the Downpipe/Header may have come out when undoing the nuts in a prior step. This is common. When reinstalling you can either use the 2 extra exhaust bolts and washers included or reuse the OEM hardware.
- Thread-in the O2 sensor into the O2 sensor bung, and tighten with a 22mm wrench

Step 15 — O2 Sensor Wiring Option 1

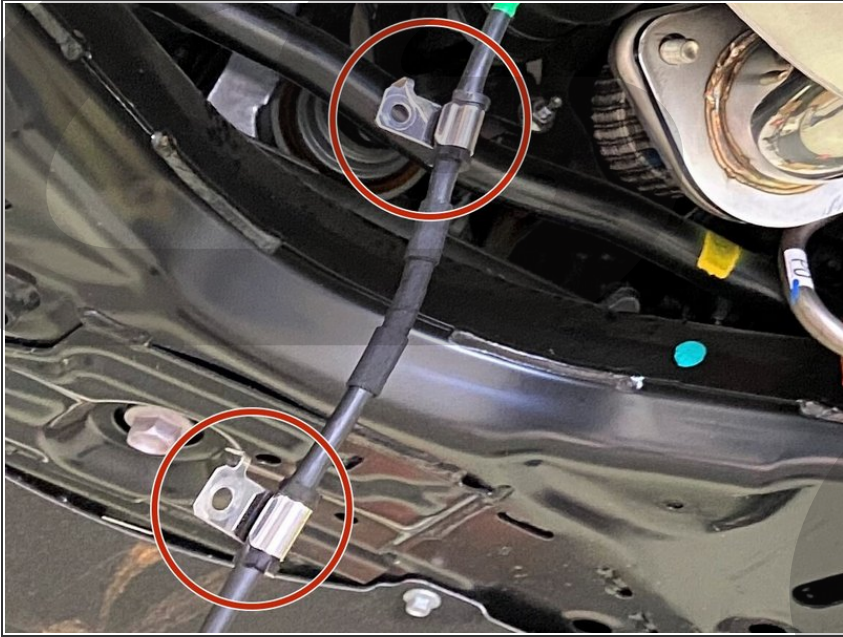

- ① There are two options that we recommend when reinstalling the O2 sensor wiring and Option 1 is shown below.
- Remove both of the metal and rubber mounts that are on the O2 wiring by separating the metal clamped to the wire
- Tuck the wiring under the Left-side Plastic Tray, with the outlet inline with the O2 sensor

Step 16 — O2 Sensor Wiring Option 2

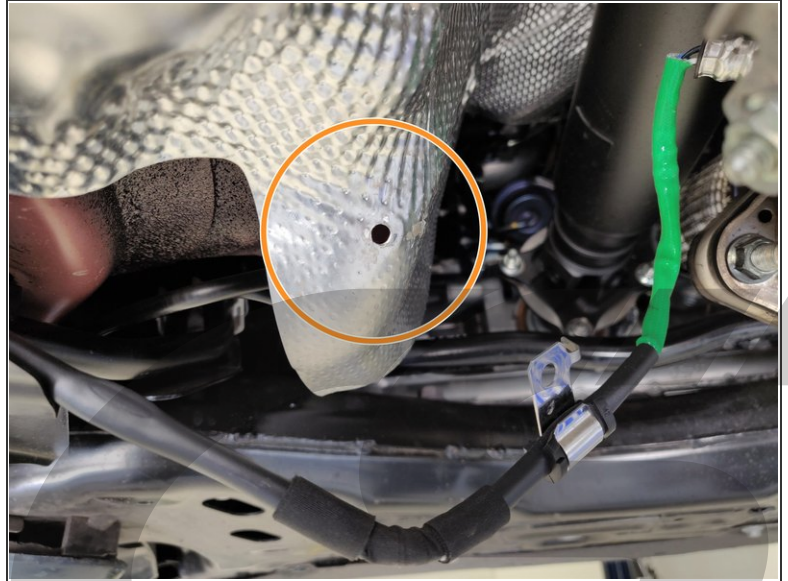
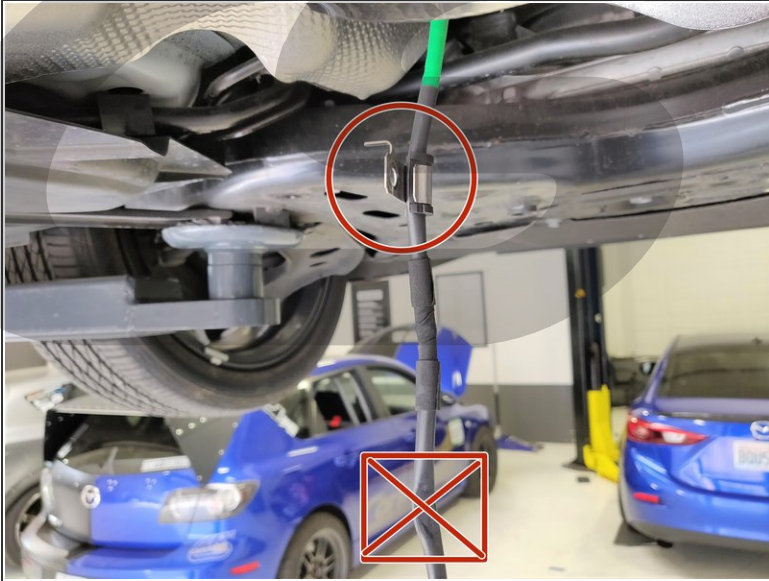

- ① **Option 2** for routing the O2 wiring is shown below and requires the included M6 hardware, a drill and a drill bit.
- Remove the metal and rubber mount that is closest to the connector end of the wiring and leave the mount that is circled.
- Select a spot in the location circled on the heat shield that can be drilled through, making sure there is enough room behind it to fit a nut and nothing behind it that could get damaged when drilling
- Drill a hole in the selected location using a 1/4" drill bit. Secure the O2 wiring by using the included hardware and the bracket on the O2 wiring and tightening it to the heat shield.
- ① The metal tab on the bracket might need to be bent straight to fit flush against the heat shield

Step 17 — Install Axleback Exhaust - Part 1



- ⓘ We recommend leaving as much protective packaging in place as possible to prevent damage to the axle back or vehicle during installation. It is shown removed for clarity.
- ⚠ We recommend having a friend assist with the CS axle back installation.
- Lift the CorkSport axle back into place and install the metal hangers into all Four(4) OEM rubber exhaust hangers
 - ⓘ Lubricant spray on the rubber hangers is recommended for easier install. Silicone spray or glass cleaner works well
- Gather the Axleback connection pipe and **loosely** install onto the Axleback with the shown hardware, **ensuring the floating flanges** are aligned and mated together

Step 18 — Install Axleback Exhaust - Part 2



- Align the Axleback Connection Pipe flange with the OEM or CS Midpipe flange
- If you are only installing the Axleback and using the OEM midpipe, ensure the OEM Gasket is still present and undamaged. If the gasket is damaged, it must be replaced.
 - ⓘ Mazda OEM Gasket Part Number: **PE23-40-305**
- Connect the CS Axleback exhaust with the OEM midpipe with the provided hardware as shown
 - ⓘ When aligning with the OEM flange, visually ensure the gasket is making even contact with both flanges and the flanges are parallel all around. If not, adjust alignment. Use a Hydraulic jack or a friend to hold the alignment while tightening to ensure proper fitment
- If you are installing the Full Catback System: Connect the Axleback and Midpipe sections with the provided hardware
 - ⓘ Use the large gasket that matches the shape of the flanges on the Axleback section and its connection pipe
- **Tighten hardware to 35 ft-lbs (47 Nm)**

Step 19 — Align CorkSport Axleback Exhaust

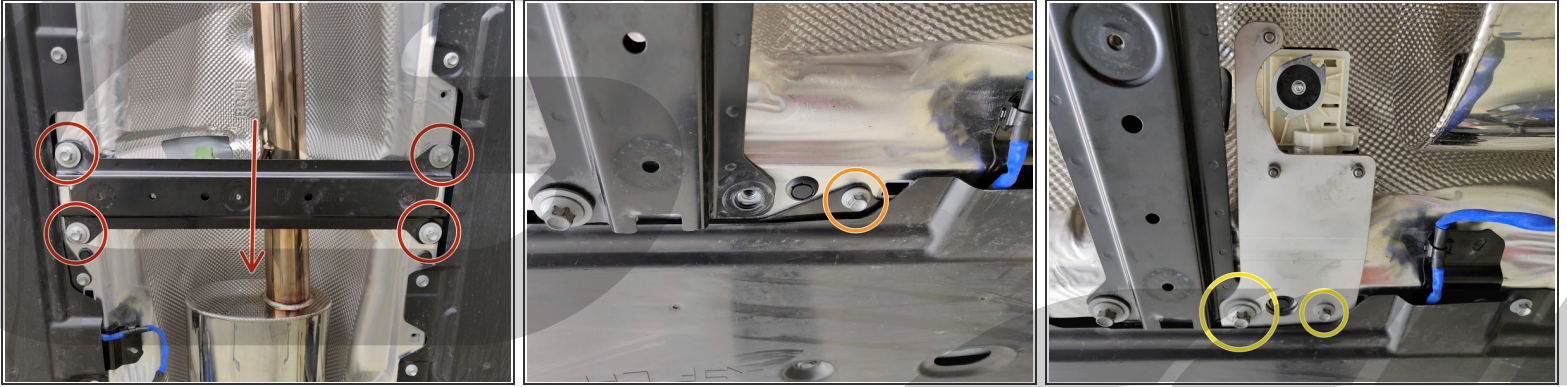

- Step back from the vehicle and observe the Tip Positions in the bumper cutouts. There should be an even gap all around the tip
- If there is not an even gap, maneuver the Axleback using the ball & socket flange until the tip fitment is even
- Once happy with the Axleback fitment, tighten the floating flange connection to **35 ft-lbs**
 - Ensure both bolts are tightened evenly. This can be seen by counting the threads shown at the end of the bolt. The number of the threads showing will be identical if each bolt is identically tightened
- Inspect the ball & socket connection all around. If there are any gaps, adjust alignment and retighten the hardware
- If still unsatisfied with fitment, loosen the above connection and repeat until satisfied with fitment
- ⓘ The ball & socket flange has a lot of adjustability and as a result may take a few tries to get fitment perfect. Having a friend help hold the axleback in the correct position while you tighten the flange will help make it easier

Step 20 — Non-Turbo Vehicles - Install the Cylinder Deactivation Bracket

- ① This step is only necessary for Non-Turbo vehicles equipped with Cylinder Deactivation
- Place the front brace back into the slots and slide it forward to line up the holes and then reinstall the four bolts using a 12mm socket and tighten down to 15-17 ft-lb.
- Remove the bolt circled using a 10mm socket and wrench.
- Install the Cylinder Deactivation bracket as shown using the 10mm bolt that was just removed and the remaining 12mm bolt from the front brace.
- Remove the metal and rubber mount from the wiring and route it to reconnect it to the motor.

Step 21 — Reassemble the Vehicle



- Reinstall the Front and Rear Underbody Bracing
- Reattach the Left and Right Plastic Undertrays
- Reattach the Silver Heat Shield

Step 22 — Installation Complete



- This completes your installation of the CorkSport Performance Mazda CX50 Exhaust System!
- ⓘ Before the first start, wipe down the exhaust with a cleaning agent and clean towel to remove any grease, dirt, or fingerprints. These can become baked into the exhaust with heat and become extremely difficult to remove
- ⓘ Listen for any strange noises upon start up and the first drive. If any are present, inspect exhaust hangers & connection points
- ⓘ A slight "burning off" smell will be present as the exhaust is heated for the first time. This should dissipate within the first few drives
- Contact us with any questions or concerns at sales@corksport.com or (360) 260-2675.
- Share your experience using #CorkSport on Instagram, Facebook, and Twitter.