

CorkSport Mazda 3 Axle Back Exhaust

2014+ Mazda 3

Sedan Axle-back Section:

- 1)-One (1) CorkSport Axle-back Section for Sedan
- 2)-Exhaust Bolt Kit:

Two (2) M10x1.25x35mm Bolts
Two (2) M10x1.25 Nut
Two (2) M10 Lock Washers
Four (4) M10 Flat Washers

Hatch-back Axle-back Section:

- 1)-One (1) CorkSport Axle-back Section for Hatch-back
- 2)-Exhaust Bolt Kit:

Two (2) M10x1.25x35mm Bolts
Two (2) M10x1.25 Nut
Two (2) M10 Lock Washers
Four (4) M10 Flat Washers

Mid-pipe Section:

- 1)-CorkSport Mid-pipe Section for Hatch-back and Sedan

One (1) Resonated section
One (1) Rear Mid-pipe section

- 2)-Exhaust Gasket & Bolt Kit:

One (1) 60mm Exhaust Gasket
Two (2) M10x1.25x35mm Bolts
Two (2) M10x1.25 Nut
Two (2) M10 Lock Washers
Four (4) M10 Flat Washers

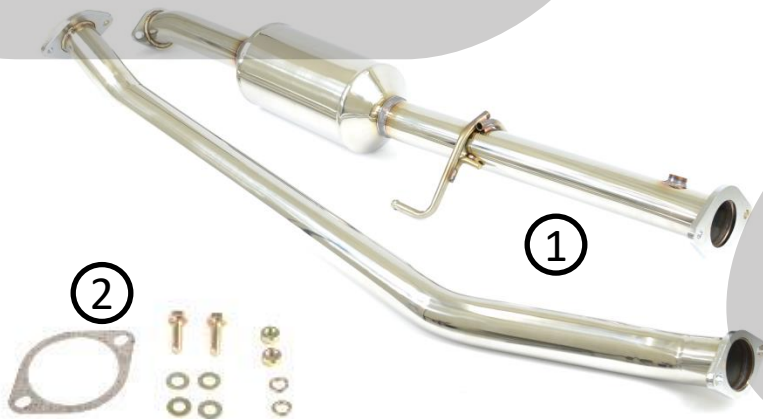
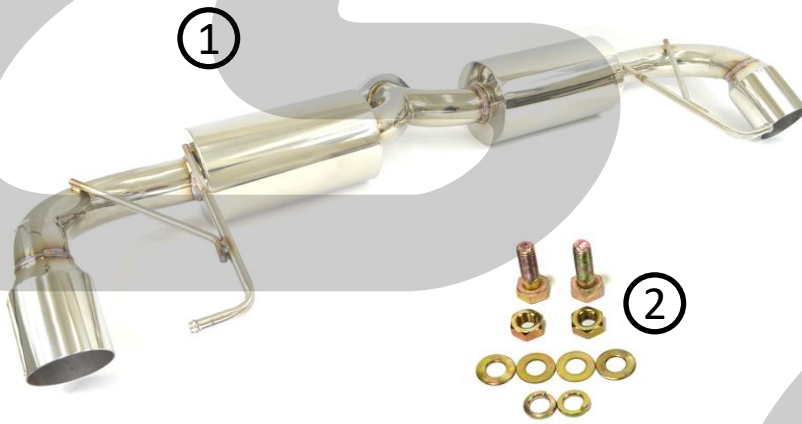

CorkSport Mazda 3 Exhaust

2014+ Mazda 3 Hatch-back & Sedan



Thank you for purchasing the CorkSport Exhaust for the 2014+ Mazda 3. Constructed from fully polished T-304 stainless steel, the CorkSport exhaust combines a deep exhaust note with quality construction while adding the performance and appearance that truly befit the great looks of the Mazda 3. Please let us know what you think by submitting a review at:

<http://www.corksport.com/corksport-2014-mazda-3-axle-back-exhaust.html>

Pre-Installation Notes:



Make sure your vehicle is completely cooled down prior to starting installation. If you are going to work on your car within an hour or two of having driven it, use a fan to cool off the car.



These instructions were written for reference only and the use of a factory service manual is recommended. Please read these instructions thoroughly prior to starting installation.



These installation instructions were written using a 2014 Mazda 3 hatch-back and sedan. Installation for 2014+ Mazda 3 will be similar.

Materials and Time:



General Info.

Part #: Axm-6-101
Time Est: 1-2 hour
Wrench Rating: 2/5



Tooling List

14mm Socket
17mm Socket
14mm End Wrench
17mm End Wrench
3/8" Drive Ratchet
6" Extension



Parts List

21mm O2 Sensor
Wrench
WD-40
Jack Stands
Floor Jack
Torque Wrench
Refer to front page for included hardware

Need Help With Your Installation?

Call (360) 260-CORK

Order of Operations & Table of Contents

Follow the order of operations listed below for your purchased exhaust system.



For 2014+ Mazda 3 Hatch-Back Axle-Back Only Use: Part# AXM-6-101-10

Section 1: Support the car on floor Jack/Jackstands or Lift	Pg. 2
Section 2: Remove the OEM Muffler Assembly	Pg. 3
Section 5: Install the CorkSport Axle-Back Exhaust	Pg. 9



For 2014+ Mazda 3 Sedan Axle-Back Only Use: Part# AXM-6-111-10

Section 1: Support the car on floor Jack/Jackstands or Lift	Pg. 2
Section 2: Remove the OEM Muffler Assembly	Pg. 3
Section 5: Install the CorkSport Axle-Back Exhaust	Pg. 9



For 2014+ Mazda 3 Hatch-Back Cat-Back Only Use: Part# AXM-6-100-10

Section 1: Support the car on floor Jack/Jackstands or Lift	Pg. 2
Section 2: Remove the OEM Muffler Assembly	Pg. 3
Section 3: Remove the OEM Mid-Pipe	Pg. 4
Section 4: Install the CorkSport Mid-Pipe Exhaust	Pg. 6
Section 5: Install the CorkSport Axle Back Exhaust	Pg. 9



For 2014+ Mazda 3 Sedan Cat-Back Only Use: Part# AXM-6-100-12

Section 1: Support the car on floor Jack/Jackstands or Lift	Pg. 2
Section 2: Remove the OEM Muffler Assembly	Pg. 3
Section 3: Remove the OEM Mid-Pipe	Pg. 4
Section 4: Install the CorkSport Mid-Pipe Exhaust	Pg. 6
Section 5: Install the CorkSport Axle Back Exhaust	Pg. 9

Detailed Instructions

1. Support the Car on Floor Jack/Jackstands or Lift

- a) Use a floor jack and jackstands to gain access to the underside of the vehicle. You will need to access both the mid-pipe exhaust section and axle-back exhaust section. Shown in **Figure 1a**.



Always refer to the floor jack and jackstand manufacturers instructions as well as the factory owners manual for your vehicle to determine jacking points and support points. Alternately, use an automotive lift to gain access to the underside of the vehicle. Redundant support mechanisms are recommended.

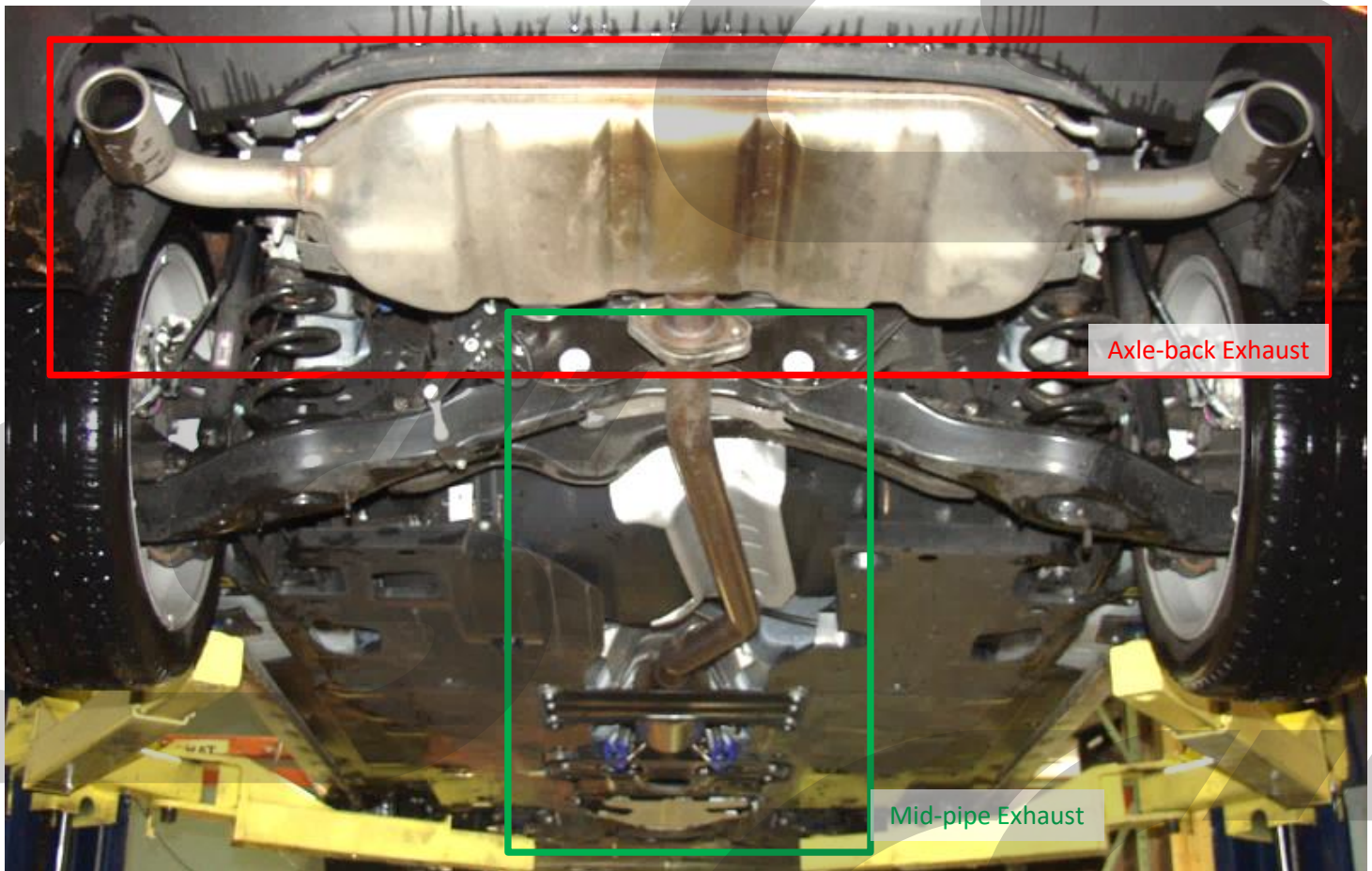

Figure 1a



The mid-pipe section for the sedan and hatch-back are the same part number, therefore interchangeable. The axle-back section for the sedan and hatch-back differ only by the exhaust tip design and orientation.

2. Remove the OEM Muffler Assembly

- a) **Jack up and support the vehicle using factory jacking and jack stand points.** Refer to the owners manual for correct positions of jack and jack stands.

- b) **Using a 14mm socket and end wrench, remove the two bolts and two nuts holding the factory exhaust to the cat pipe (bolts circled in [Figure 2a](#)).**

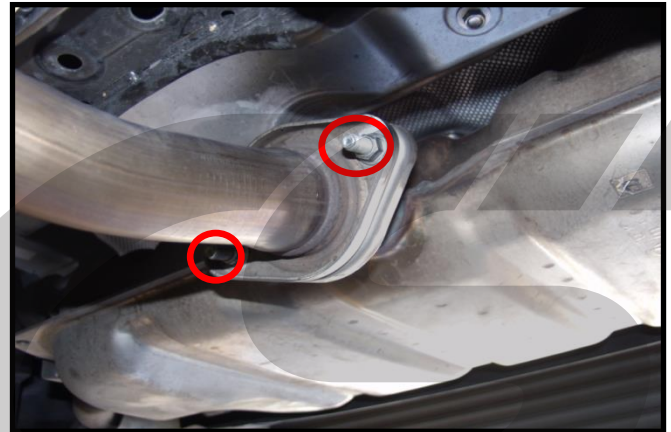

Figure 2a

- c) **Remove the exhaust from the four rubber exhaust hangers located on either side of the muffler (shown in [Figure 2b](#)).** Start with one side and remove the exhaust hanger from the rubber hanger. This can be made easier with WD40. The exhaust will be supported by the other hangers on the opposite side. While supporting the center of the muffler, remove the last two exhaust hangers from the rubber hangers.



Figure 2b



Support the muffler as you remove it from the car to keep it from falling to the ground. The easiest way is to get a friend to help you or use a floor jack.

3. Remove the OEM Mid-Pipe

- a) **Remove the cat heat shielding.** Pry out the four(4) plastic push clips with a flat blade screw driver (green arrows in Figure 3a).
- b) **Use a 10mm socket wrench to remove the five (5) bolts (green circles in Figure 3a).**

- c) **Remove the cat skid protection plate.** Un bolt the six (6) 12mm bolts (red circles) with a socket wrench. Slide the plate to one side to free it from the under body aero panels (Figure 3a).

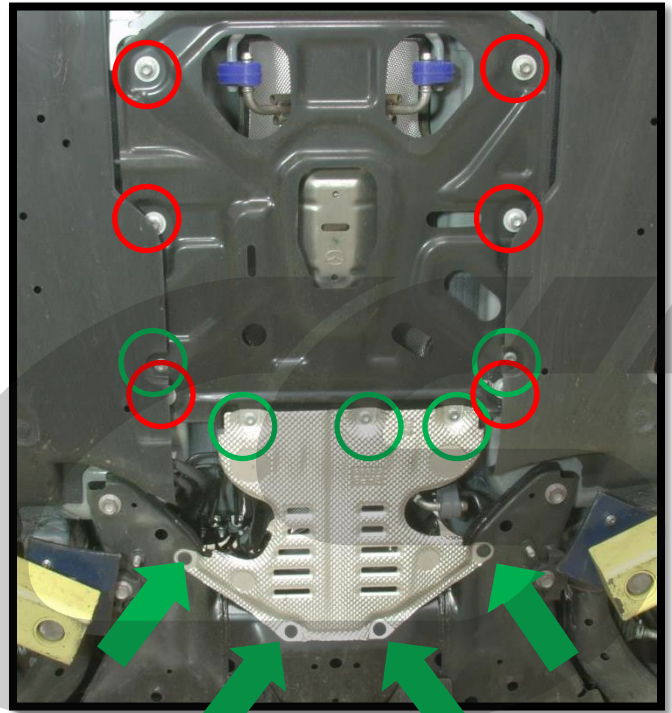

Figure 3a

- d) **Remove the mid body chassis brace** by using a 12mm socket to remove the six (6) bolts (red circles in Figure 3b).



Support the exhaust pipe as you remove the mid chassis brace from the car to keep the exhaust from falling to the ground. The easiest way is to get a helper or use a jack.

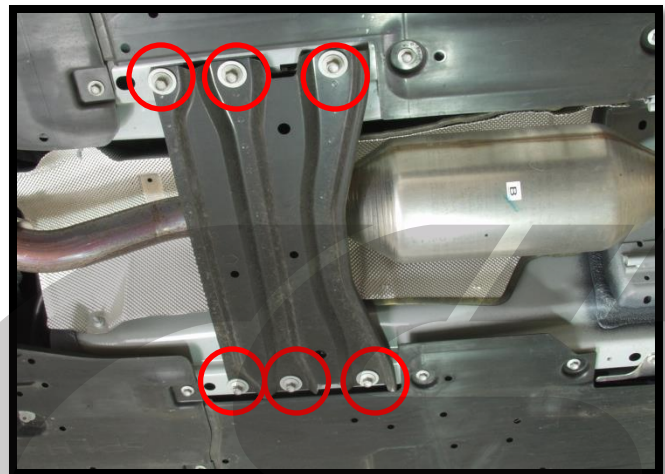

Figure 3b

Part #AXM-6-100

3. Remove the OEM Mid-Pipe

- e) Remove the o2 sensor harness from the metal clips fastened to the cat. Use a flat blade screw driver to pry open the clip and pull the harness free (Figure 3c).
- f) Remove the o2 sensor (red arrow) by turning it counter-clockwise with a 21mm o2 sensor wrench. Let the sensor hang down from the wiring (Figure 3c).



Apply WD-40 to the threads of the o2 sensor then tighten and untighten if it does not remove easily.

- c) Un-fasten the cat from the downpipe by removing the two (2) 14mm nuts (red circles) with a 14mm deep socket wrench (Figure 3d).

- d) Lubricate the two (2) blue rubber hangers with WD-40 and pull the exhaust free from the vehicle (Figure 3e).

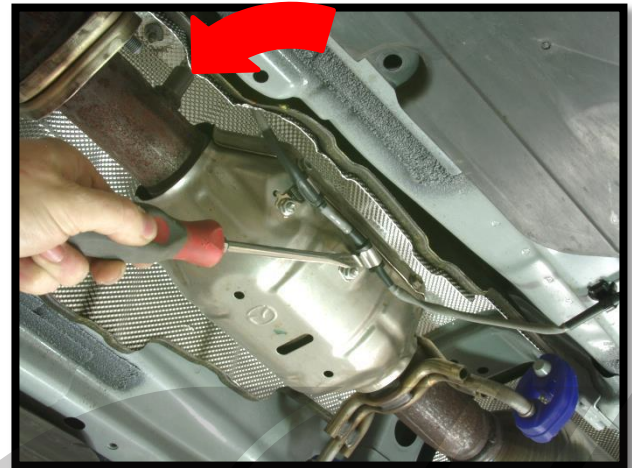

Figure 3c

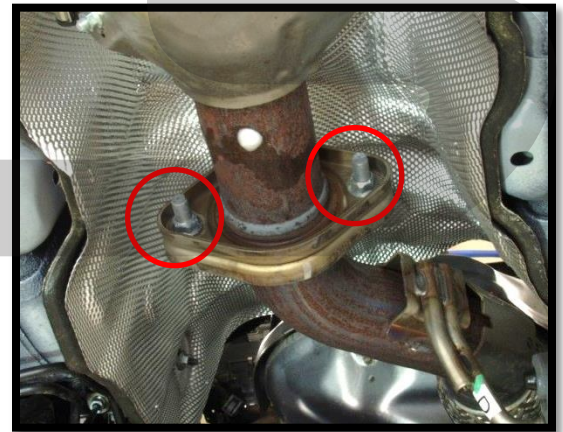

Figure 3d

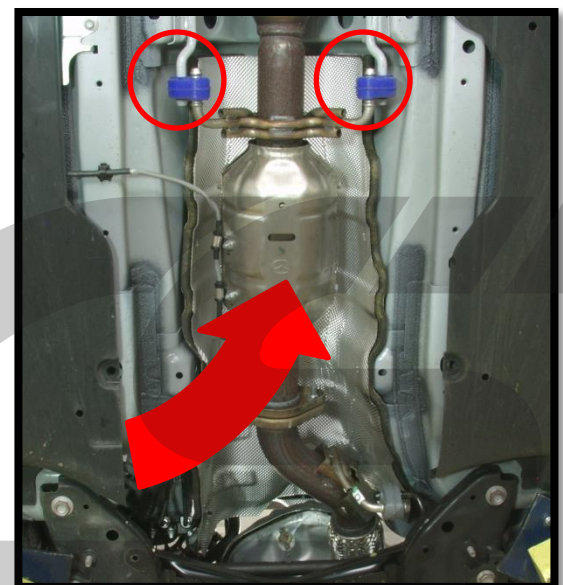

Figure 3e

4. Install the CorkSport Mid-Pipe Exhaust

a) Place the forward section of the CorkSport exhaust pipe into the blue rubber hangers (blue arrows in Figure 4a). Verify that the o2 sensor bung is placed upward and toward the front of the vehicle (green arrow in Figure 4b).

b) Replace the mid chassis brace and fasten it in place with the six (6) 12mm bolts (red circles in Figure 4a). Torque to 15-17ft-lbs.

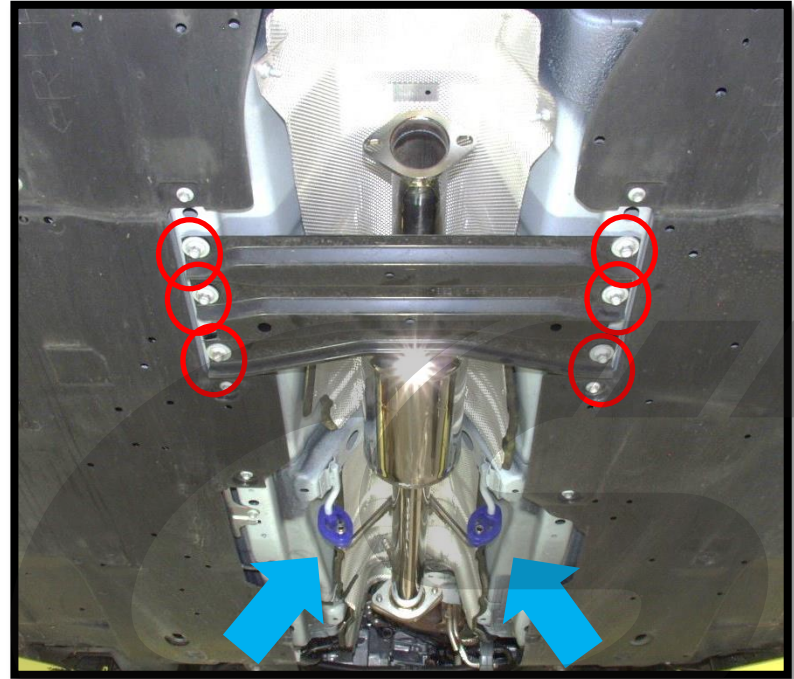

Figure 4a

c) Verify the factory exhaust gasket is still attached to the downpipe (red arrow) and guide the downpipe studs into the flange holes of the CorkSport exhaust pipe (Figure 4c).



Figure 4b

d) Push the downpipe and CorkSport exhaust pipe together. The protruding pipe going past the gasket on the downpipe will slip inside of the CorkSport exhaust flange.



Figure 4c

4. Install the CorkSport Mid-Pipe Exhaust (Continued)

e) Coat the downpipe studs with anti-seize lubricant. Replace the two (2) 14mm nuts (red circles) and fasten the exhaust flanges together (Figure 4d). Torque the nuts 35ft-lbs.

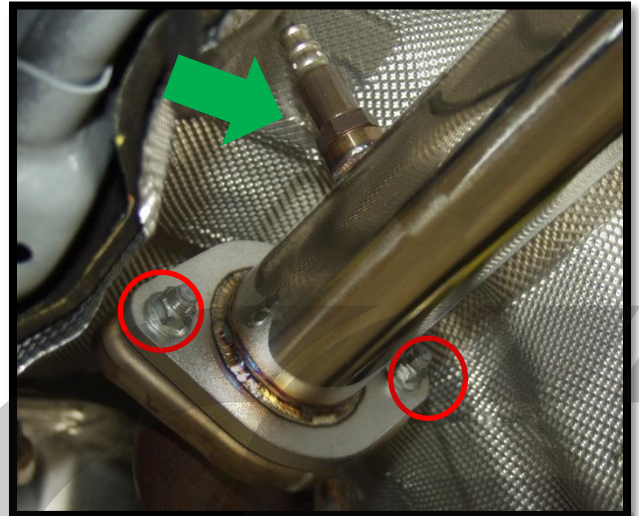

Figure 4d

f) Coat the threads on the o2 sensor with anti-seize and fasten it back into the o2 bung in the exhaust with an o2 sensor wrench (green arrow in Figure 4d).



Figure 4e

g) Transfer the gasket from the factory exhaust flange to the end of the CorkSport mid section exhaust pipe (Figure 4e).



The CorkSport mid section pipe only has one flange with the pipe protruding for gasket placement. This end of the pipe will be installed toward the rear of the vehicle.

4. Install the CorkSport Mid-Pipe Exhaust (Continued)

- h) **Attach the CorkSport mid section to the forward section.** Use the supplied 60mm exhaust gasket and hardware. Line the two flanges up and tighten the 17mm hardware with an end wrench and socket wrench (Figure 4f & 4g). Torque the two bolts to 45ft-lbs.

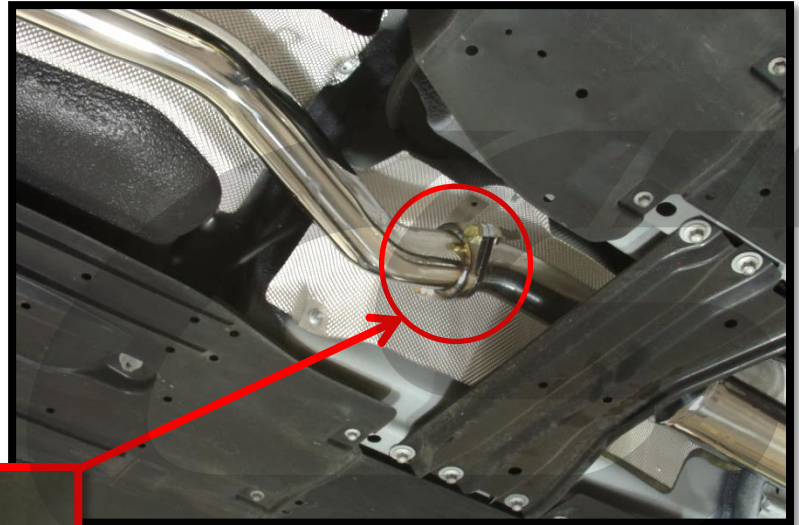
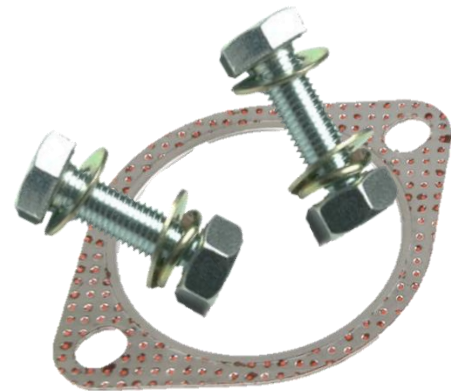

Figure 4f

Figure 4g



60mm Exhaust Gasket



Let the end of the pipe hang while you install the axle back section of the exhaust in the next section

5. Install the CorkSport Axle Back Exhaust

- a) **Install the CorkSport axle back exhaust.** Place the two exhaust hangers into the two (2) rear stock rubber exhaust hangers and position the exhaust into place (red arrows in Figure 5a).



The two (2) forward factory rubber hangers are not used. They may be left in place.

Mazda 3 Hatchback



The hatchback requires the use of provided polyurethane exhaust hangers. Shown right.

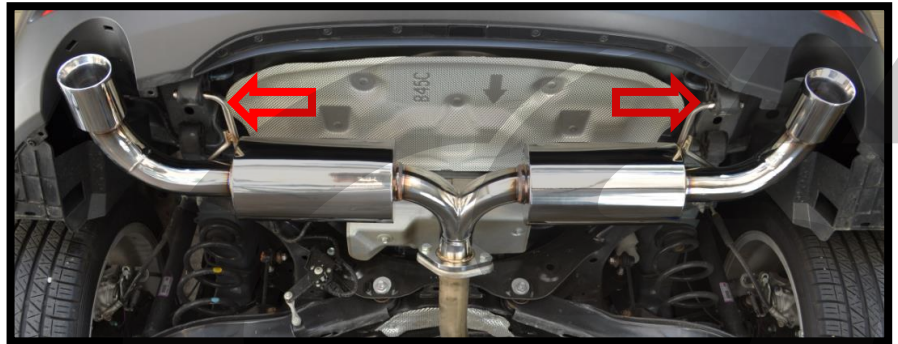

Mazda 3 Sedan

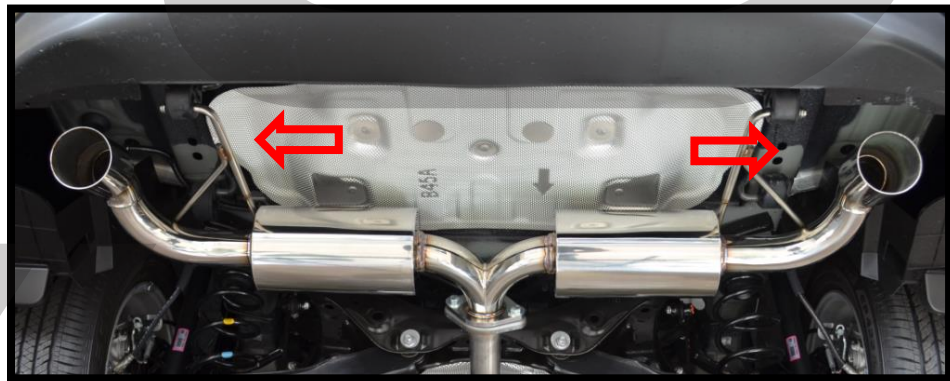
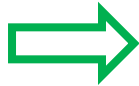

Figure 5a

- b) **Reusing the factory gasket, install the provided hardware** in the order, bolt, washer, exhaust flanges, second washer, lock washer, then finally the nut (Figure 5b). Hand tighten.



Support the muffler section with the use of a helper or jack.

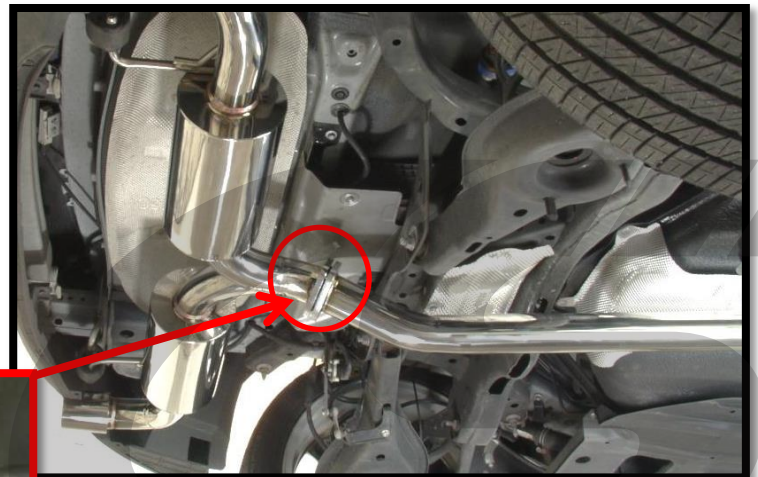
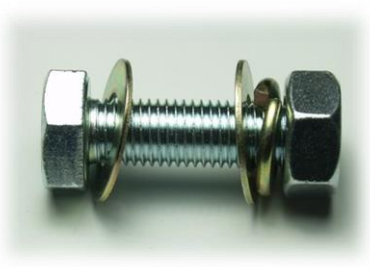

Figure 5b

5. Install the CorkSport Axle Back Exhaust Contuued..

- c) **Align the exhaust tips and hangers so the exhaust is straight and centered.** Figure 5c and Figure 5d show how the exhaust tip should look when properly aligned.



The tips of the exhaust should fit perfectly within the arched exhaust cut outs in the bumper and should not rub the under body heat shields or sub frame.

Mazda 3 Hatchback

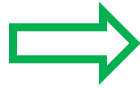

Misalignment of the axle back muffler section could result in melting the exhaust cut out sections of the bumper cover. Make sure there is at least a one inch gap between the exhaust tip and the bumper.



Figure 5c

Mazda 3 Sedan



Misalignment of the axle back muffler section could result in melting the lower bumper cover. Make sure there is at least a one inch gap between the exhaust tip and the bumper.



Figure 5d

- d) **If adjustment of the stainless exhaust hangers is necessary**, simply bend the metal hanger with a large pair of channel lock pliers or pry bar.

5. Install the CorkSport Axle Back Exhaust (continued)

- e) Tighten all the hardware to 25ft-lbs with a 17mm socket and end wrench.

Mazda 3 Hatchback



Figure 5e

- f) Recheck tip position for interference. Figure 5f and Figure 5e show how the final exhaust should fit.

Mazda 3 Sedan

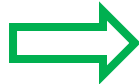
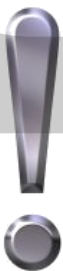

Figure 5f



This completes the installation of your CorkSport Axle Back Exhaust. Bring the car down off the jack stands and start the car. Use a flashlight to check under the car to ensure that you do not see any visible exhaust fumes and listen for leaks (usually a whispering tick sound at the flange). If there are leaks, 99% of the time a flange has been over tightened or is misaligned. There may be a burning off smell as the exhaust is heated for the first time. This smell will go away after some driving.